

# MODEL ORDER SELECTION CRITERION FOR MONITORING HAEMOGLOBIN STATUS IN DENGUE PATIENTS USING ARMAX MODEL

H. Abdul Rahim<sup>1</sup>, F. Ibrahim<sup>2</sup> *Member IEEE*, M. N. Taib<sup>3</sup> *Senior Member IEEE*, R. Abdul Rahim<sup>1</sup>, and Y. Mad Sam<sup>1</sup>

<sup>1</sup>Department of Control and Instrumentation Engineering, Faculty of Electrical Engineering, Universiti Teknologi Malaysia, 81310 UTM Skudai, Johor, Malaysia.

<sup>2</sup>Department of Biomedical Engineering, Faculty of Engineering, University of Malaya, 50603 Kuala Lumpur, Malaysia.

<sup>3</sup>Faculty of Electrical Engineering, Universiti Teknologi Mara, 40450 Shah Alam, Selangor, Malaysia.

*Abstract - This paper describes the development of linear autoregressive moving average with exogenous input (ARMAX) models to monitor the progression of dengue infection based on hemoglobin status. Three different ARMAX model order selection criteria namely Final Prediction Error (FPE), Akaike's Information Criteria (AIC) and Lipschitz number have been evaluated and analyzed. The results showed that Lipschitz number has better accuracy compared to FPE and AIC. Finally based on Lipschitz number, appropriate model orders have been selected to monitor the progression of dengue patients based on hemoglobin status. Further work is to apply this appropriate model orders to nonlinear Autoregressive (NARMAX) model.*

## I. INTRODUCTION

Dengue hemorrhagic fever (DHF) is an infection associated with an increase in microvascular permeability, a decrease in plasma volume, and in severe forms hypotension and shock [1, 2]. A significant percentage of DF patients develop a more severe form of disease, known as dengue hemorrhagic fever (DHF). DHF is an infection associated with an increase in micro vascular permeability, a decrease in plasma volume, and in severe forms hypotension and shock [3]. Dengue virus infections may be asymptomatic or may lead to undifferentiated fever, DF or DHF with plasma leakage that may lead to hypovolaemic shock (dengue shock syndrome, DSS). Figure 1 shows the manifestations of dengue virus infection [3].

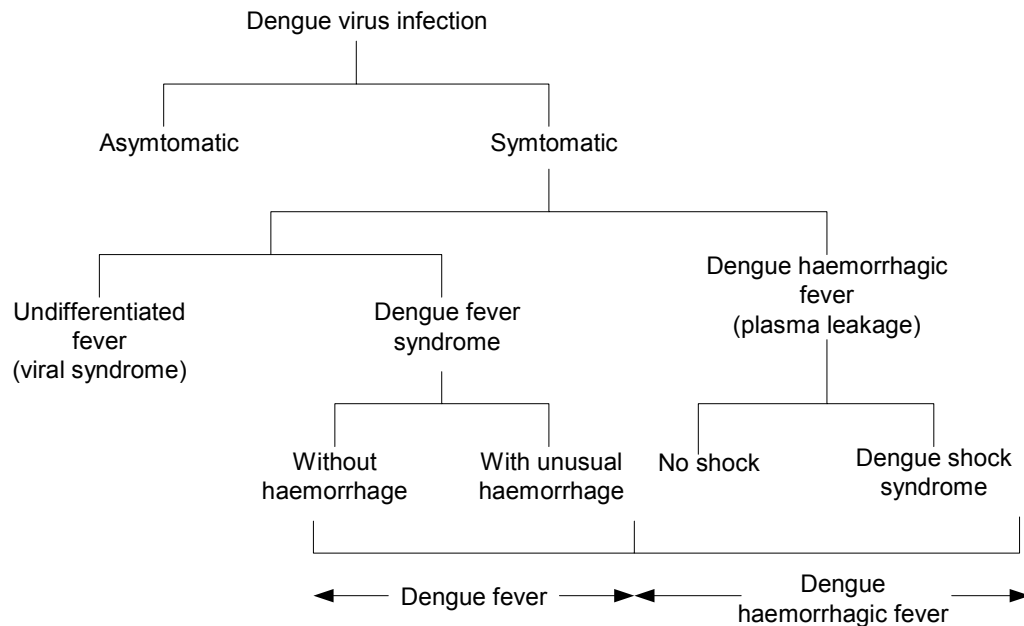

Figure 1. Manifestations of dengue virus infection.

In order to monitoring the risk in DHF patients, two conventional techniques are using. First technique is monitoring the onset and progression of plasma leakage by measuring the total increase in hematocrit (Hct) (over 20%) or hemoglobin (Hb) concentration (Hb above the upper normal range limit) [3]. Second conventional method for monitoring the risk in DHF patients is to monitor their platelet count [3]. These techniques are considered as invasive, tedious, and time-consuming. Furthermore, frequent blood taking will cause further injury to the subcutaneous tissue and potentially risky to the DHF patients [4]. Ibrahim et al [5] has introduced a new approach in modeling the Hb non-invasively using bioelectrical impedance analysis (BIA) technique. This model seems promising, however, its prediction accuracy is low and can be improved using an advanced signal processing.

Linear model is one in which the independent variable is added or multiplied together with the parameters. Linear refers to the form of the differential equations, not the predicted behavior of the system. If the system is stable, then the output is proportional to the output. If the input increases by, say 50%, the output will increase by 50% too.

Parameter estimation or system identification of continuous-time systems is an important subject and has numerous applications ranging in control, signal processing, astrophysics and economics [1]-[7]. This is because most physical systems or phenomena are continuous time in nature. In spite of this, due to the advent of digital computers, research of control and identification of these continuous-time system

and process has concentrate on their discretized models with the samples from the underlying continuous-time system inputs and outputs. One particular interesting and practical scenario is the identification-time systems using discrete data. The ARX model give a better performance in food package detection [6] and also in control area [7-9]. ARX model is also better suited. to model the vascular system between aorta and radial artery [10].

The purpose of this paper is to analyze the performance of three different types of order selection criteria for linear autoregressive moving average with exogenous (ARMAX) models. This linear ARMAX models is used to monitor the progression of dengue patients based on hemoglobin status. Outline of the paper is as follows: Section II presents the linear autoregressive moving average with exogenous input (ARMAX) model. In Section III gives a brief review three types of moder order selection such as Akaike's Information Criteria (AIC), Final Prediction Error (FPE) and Lipschitz number. Sections IV describe the basic of Receiver Operating Characteristics (ROC) curves. The methodology of the study is provided in Section V, while In Section VI presents the results. Finally, concluding remarks and discussions are presented in Section VII.

## II. AUTOREGRESSIVE MOVING AVERAGE WITH EXOGENOUS INPUT (ARMAX) MODELS

The ARMAX model deals with the lack of flexibility of the disturbance term properties by the ARX model. Flexibility is added by introducing the equation error which is a moving average of white noise [11].

The model equation can express as:

$$G(z, p) = \frac{B(z)}{A(z)}, \quad H(z, p) = \frac{C(z)}{A(z)} \quad (1)$$

with

$$A(z) = 1 + a_1 z^{-1} + \dots + a_{n_a} z^{-n_a}$$

$$B(z) = b_1 z^{-1} + \dots + b_{n_b} z^{-n_b}$$

$$C(z) = 1 + c_1 z^{-1} + \dots + c_{n_c} z^{-n_c}$$

where  $G(z, p)$  and  $H(z, p)$  are filters of finite order and functions of a parameter vector  $p$ ,

$$p = [a_1 \dots a_{n_a} \quad b_1 \dots b_{n_b} \quad c_1 \dots c_{n_c}]^T$$

The ARMAX model is a standard tool in control and econometrics for both system description and control design [11]. Figure 2 shows the ARMAX model structure.

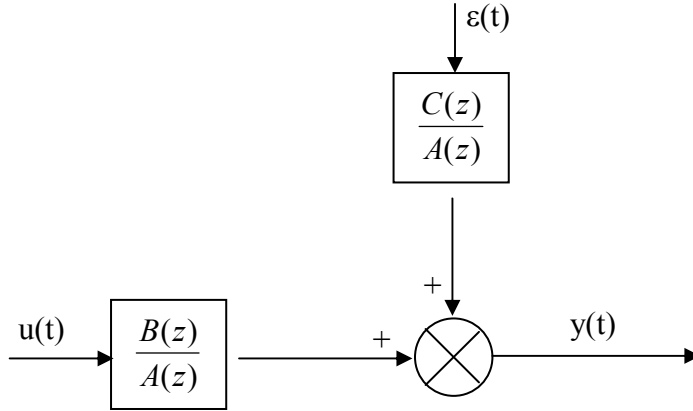

Figure 2. The ARMAX model structure

### III MODEL ORDER SELECTION

Model order selection is dependent upon the quality of the model since the model order is varied and the cost function is monitored. A useful measure to aid this procedure is to measure the significance of each additional mode. Assessing the significance of each mode is not only necessary for model order selection but also for further analysis of the estimated model and can aid the design and analysis of control systems.

Some of the popular model order selections are Akaike's information criterion (AIC), Final prediction error (FPE) and Lipschitz number which are used in this thesis.

#### a. Akaike's Information Criterion (AIC)

AIC originally proposed by Akaike [12], attempts to select a good approximating model for inference based on the use of the relative entropy, or the Kullback-Leibler (K-L) information., as a fundamental basis for model order selection. The AIC criterion is given as:

$$AIC = N \log\left(\frac{SSE}{N}\right) + 2p \quad (2)$$

with  $SSE$  the sum of squared errors,  $N$  is the number of data points and  $p$  the number of parameters in the model. The first term in Equation 3.24 decreases with increasing  $p$  (increasing complexity) while the second term penalizes too complex (overparametrized) models. The model structure with the smallest criterion value is selected. This selection criterion was designed for models fitted by least squares.

b. Final Prediction Error (FPE)

The FPE criterion is similar to the AIC criterion, but with a different penalizing term:

$$FPE = \frac{SSE}{N} \left( 1 + \frac{2p}{N-p} \right) \quad (3)$$

The FPE criterion only holds for selection among model structures, which are flexible enough to include the true system. In a model structure selection application one will also have to consider underparametrized model structures. For such structures, Equation 3.25 loses its interpretation as an estimate of the “final prediction error”. Nevertheless, Equation 3.25 can still be used to assess the difference between the prediction ability of various underparameterized model structures.

c. Lipschitz number

He and Asada [13] introduced this method for the estimation of the model orders of nonlinear input-output models. The approach is based on the continuity property of nonlinear functions, which represents input-output models of continuous dynamic systems. By evaluating the modification of an index, which is defined as Lipschitz number with successive modification of the model orders, the appropriate model orders can be determined more simply and reliably. Consider the following input-output model

$$y(t) = F(y(t-1), \dots, y(t-n_y), u(t-1), \dots, (t-n_u)) \quad (4)$$

where  $n_u$  and  $n_y$  are the input and output lags, which correspond to  $n_b$  and  $n_a$  in [14] if the function  $F$  in the above equation is linear. Assume that a data set of  $N$  input-output pairs exists and the following regressor matrix can be formulated:

$$\varphi^T(t) = [y(t-1), \dots, y(t-n_y), u(t-1), \dots, (t-n_u)] \quad (5)$$

so that

$$y(t) = F(\varphi(t), \theta) \quad (6)$$

where  $\theta$  is the parameter vector. The partial derivatives of the function  $F$  with respect to its arguments are assumed to be bounded.

$$|F_i| = \left| \frac{\partial F}{\partial \varphi_i} \right| \leq M, \quad i = 1, 2, \dots, n \quad (7)$$

where  $n$  refers to the total number of regressors. For all combinations of input-output pairs, the Lipschitz quotient is now introduced:

$$q_{ij} = \left| \frac{y(t_i) - y(t_j)}{\varphi(t_i) - \varphi(t_j)} \right| \quad i \neq j \quad (8)$$

where  $\| \cdot \|$  specifies the Euclidean norm. The Lipschitz condition then states that  $q_{ij}$  is always bounded, if  $F$  is continuous. Consider now the differences  $\partial y = y(t_i) - y(t_j)$  and  $\partial \varphi_l = \varphi_l(t_i) - \varphi_l(t_j)$ . If  $\partial \varphi_l$  are very small, the following approximation holds:

$$\partial y = \frac{\partial F}{\partial \varphi_1} \partial \varphi_1 + \frac{\partial F}{\partial \varphi_2} \partial \varphi_2 + \dots + \frac{\partial F}{\partial \varphi_n} \partial \varphi_n = F_1 \partial \varphi_1 + F_2 \partial \varphi_2 + \dots + F_n \partial \varphi_n \quad (9)$$

Consequently, the Lipschitz quotient must obey:

$$q_{ij}^{(n)} = \frac{\partial y}{\sqrt{(\partial \varphi_1)^2 + \dots + (\partial \varphi_n)^2}} = \frac{|F_1 \partial \varphi_1 + \dots + F_n \partial \varphi_n|}{\sqrt{(\partial \varphi_1)^2 + \dots + (\partial \varphi_n)^2}} \leq \sqrt{n}M \quad (10)$$

According to He and Asada [13] in order to determine the optimal regressor structure the following procedure has to be followed:

- Step (1) For a given choice of lag space, determine the Lipschitz quotients for all combinations of input-output pairs.
- Step (2) Select the  $p$  largest quotients,  $p=0.01N \sim 0.02N$ . The largest quotients typically occur when the differences  $\partial \varphi_l$  are small.
- Step (3) Evaluate the criterion  $\bar{q}^{(n)} = \left[ \prod_{k=1}^p \sqrt{n}q^{(n)}(k) \right]^{\frac{1}{p}}$
- Step (4) Repeat the calculations for a number of different lag structures.
- Step (5) Plot the criterion as a function of lag space and select the optimal number of regressors as the “knee point” of the curve.

The method is time-consuming when computing all the quotients especially if  $N$  is large. It is thus a common practice to let the number of past inputs and outputs to increase simultaneously.

#### IV. RECEIVER OPERATING CHARACTERISTIC (ROC) CURVE

ROC curves display the relationship between sensitivity (true positive rate) and 1-specificity (false positive rate) across all possible threshold values that define the positivity of a disease. They show the full picture trade-off between true positive rate and false positive rate at different levels of positivity. The ANN must be trained before the ROC curve can be generated. The resulting network is referred to as a “basic trained network”. This initial instance of the ANN provides one operating point. The result is a set of instances of the network chosen to represent a point on the ROC curve. The goodness of this set of network instances are then evaluated using separate test data. Sensitivity and specificity are the basic measures of the accuracy of the diagnostic test. They describe the abilities of the test to enable one to correctly diagnose disease when the disease is actually present and to correctly rule out disease when it is truly absent. The accuracy of a test is measured by comparing the results of the test to the true disease status of the patient. Sensitivity and specificity depend on the threshold (also known as ‘operating point’ or ‘cut point’) used to define positive and negative test results. As the threshold shifts, the sensitivity increases while the specificity decreases, or vice versa.

In general, four possible decisions and two types’ errors are made when comparing a test result with a diagnosis as shown in Table 1. If both diagnosis and test are positive, it is called a true positive (TP). The probability of the TP to occur is estimated by counting the true positives in the sample and divide by the sample size. If the diagnosis is positive and the test is negative it is called a false negative (FN). False positive (FP) and true negative (TN) are defined similarly. The two sets of values produced in the threshold are the total positive and negative indicated as T+ and T-.

Sensitivity and specificity are the basic measures of the accuracy of the diagnostic test. They describe the abilities of the test to enable one to correctly diagnose disease when disease is actually present and to correctly rule out disease when it is truly absent. The accuracy of a test is measured by comparing the results of the test to the true disease status of the patient. Sensitivity and specificity depend on the threshold (also known as ‘operating point’ or ‘cut point’) used to define positive and negative test results. As the threshold shifts, the sensitivity increases while the specificity decreases, or vice versa.

Sensitivity is the ratio or percentage of a probability that a test result will be positive when the diagnosis is present and also known as true positive rate (TPR), define as:

$$\text{Sensitivity : TPR} = \frac{TP}{D+} \quad (11)$$

Specificity is the ratio or percentage of a probability that a test result will be negative when the disease is not present and also known as true negative rate (TNR), define as:

$$\text{Specificity : } TNR = \frac{TN}{D-} \quad (12)$$

Other definition such as the false negative rate (FNR) and false positive rate (FPR) are given as:

$$FNR = \frac{FN}{D+} = 1 - TPR = 1 - \text{Sensitivity} \quad (13)$$

$$FPR = \frac{FP}{D-} = 1 - TNR = 1 - \text{Specificity} \quad (14)$$

The closer the ROC curve is to 1.0, the better the diagnostic test [9]. The percentage for diagnostic accuracy (DA) refers to the percentage of samples that have been correctly diagnosed. In any test with a fixed threshold, it is desirable for a decision model to produce TPR and FPR pair nearby this point. Therefore, measurement of *Euclidean Distance (ED)* of any coordinate pairs in the plot to this ideal point would distinctively differentiate performance between models for a fixed threshold. Calculation of this *ED* from any coordinate pair can be defined as:

$$ED = \sqrt{(TPR-1)^2 + FPR} \quad (15)$$

Rough guides for classifying the accuracy of diagnostic test are as defined in Table 1.

Table 1: Accuracy of diagnostic test using ROC.

AUC	Accuracy
0.90 - 1.00	excellent
0.80 - 0.90	good
0.70 - 0.80	fair
0.60 - 0.70	poor
0.50 - 0.60	fail



## V. METHODS

The subjects in this study are formed into two groups: the first group is patients having serological confirmation (WHO 1997) of acute dengue infection. The second group is the control group for healthy female and male subjects.

These first group patients admitted in HUKM, Malaysia during the years 2001 and 2002, were prospectively studied. The severity of the DHF is classified into grade I to IV, according to WHO recommendation [3]. Acute dengue infection was confirmed subsequently by the use of ELISA to detect elevated dengue specific IgM (primary infection) and IgG (secondary infection) [15]. Patient serum samples were tested for hemoglobin determination using an automated counter (Coulter STKS machine).

All patients were required to follow the following guidelines to ensure accurate body composition results (Biodynamics 2000), no drinking and eating intake for 4 hours prior to the test, no alcohol consumption for 24 hours prior to the test, no physical exercise for 12 hours prior to the test.

The clinical data were recorded using the standardized questionnaire data collection, designed by Ibrahim et.al [2]. Since the patients were admitted at different stages of their illness, the daily progress of the patients was dated with referenced to the day of fever defeverescence. Hence, fever day 0 is defined as the day of fever subsided when the body temperature fell below 37.5°C. Days after the fever subsided is designated as fever day +1 (1 day after fever subsided), fever day +2, and onwards [16]. Previous study conducted by Ibrahim *et. al.* [5] found that four significant predictors to model Hb concentration status in dengue patients (gender, weight, reactance (Xc) and vomiting) using multivariate analysis. The model [17, 18] has been improved by Abdul Rahim, H *et. al.* [19] in the application of linear autoregressive model (AR) and linear autoregressive with exogenous input model (ARX) [20] using five predictors.

Second group of patients who do not have past medical history of dengue were recruited and studied. The subject preparation for the control data used the same guideline as in the BIA subject preparation used for first group[21]. The BIA safety measurements procedure and other safety precautions were made known to the subjects and their informed consent was obtained from each subject prior to the BIA measurement [21].

For the control subject, the weight was taken once. However for subjects with dengue infection, the weight was measured daily until upon discharged. The subjects were required to expose their right ankle and wrist during the BIA measurement [21]. Two electrodes were placed on the patient's right hand,

one the base of the knuckles and another slightly above the wrist joint. Another two electrodes were placed on the right foot, one near the toes and the other slightly above the ankle joint. A constant current less than 1 mA and single frequency of 50 kHz was produced by a biodynamic Model 450 bioimpedance analyzer (Biodynamic Corporation, USA) and injected to the base of the knuckles and base of the toes and the signal was picked up by the other two sensor electrodes. Resistance, reactance, body capacitance and phase angle were measured by the BIA analyzer.

The BIA measurement was performed with BIA-450 bioimpedance analyser (a Biodynamics Model 450(BIA 450), from Biodynamics Corporation USA). This analyzer measures bioimpedance at a single frequency of 50 kHz.

Therefore, from the analysis of the test outcomes, one would be able to identify which predictors with respect to the hemoglobin status, could be used to monitor the progression of dengue infection based on hemoglobin status.

These input variables were used to determine the order of ARMAX model. Orders of the ARMAX model chosen in this analysis are FPE, AIC and Lipschitz.

The accuracy value of hemoglobin based on model fitted was observed to evaluate the ability of the 3 different models order selection criteria chosen.

## VI. RESULTS

The system is a multi-input single-output (MISO) system. The model order for the 3 different types of models order selection criteria in autoregressive (ARX) models have been fixed.

First, the model order was chosen with three different types of order selection criteria in ARMAX model. These are the final proposed model to monitor the progression of dengue infection of the healthy and unhealthy patients. Figures 3, 4 and 5 illustrate Lipschitz number, FPE criterion and AIC criterion plots for five input variables of dengue patients and show the value of the model order (4,2,2,2), (15,3,1,1) and (25,3,8,1), respectively. The best model order based on the DA (reasonably high) and least value of error was found.

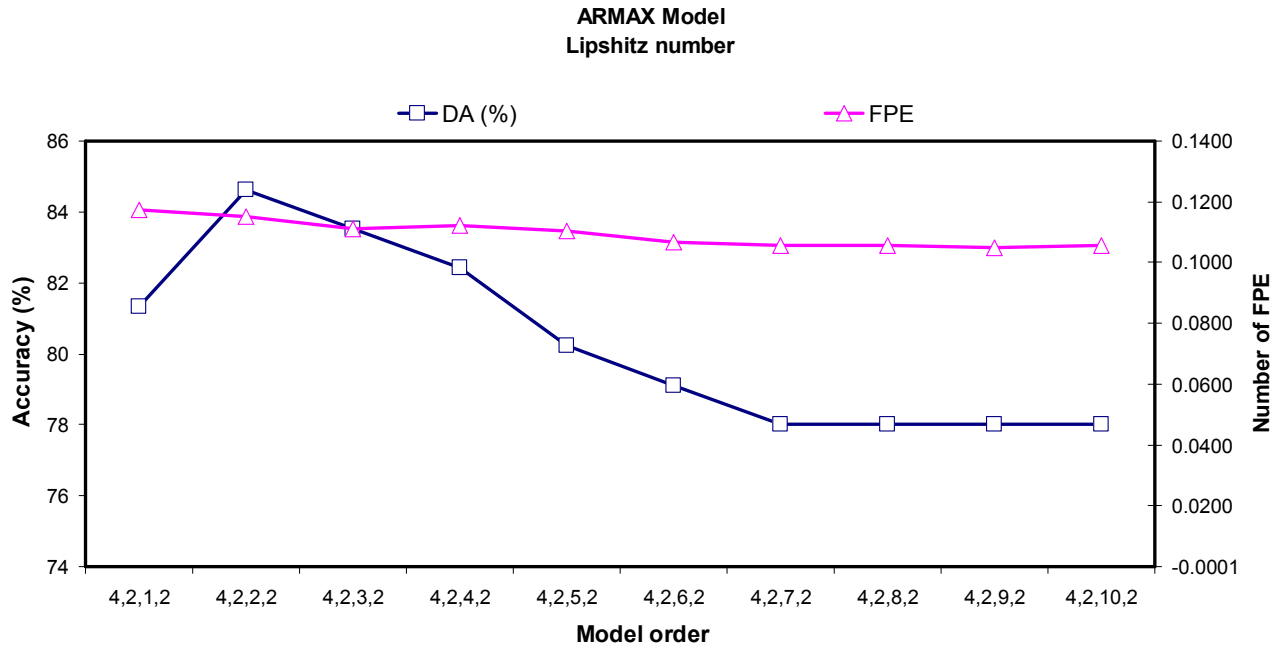

Figure 3. Plot of diagnostic accuracy and FPE against the number of model order using Lipschitz number criteria via ARMAX model

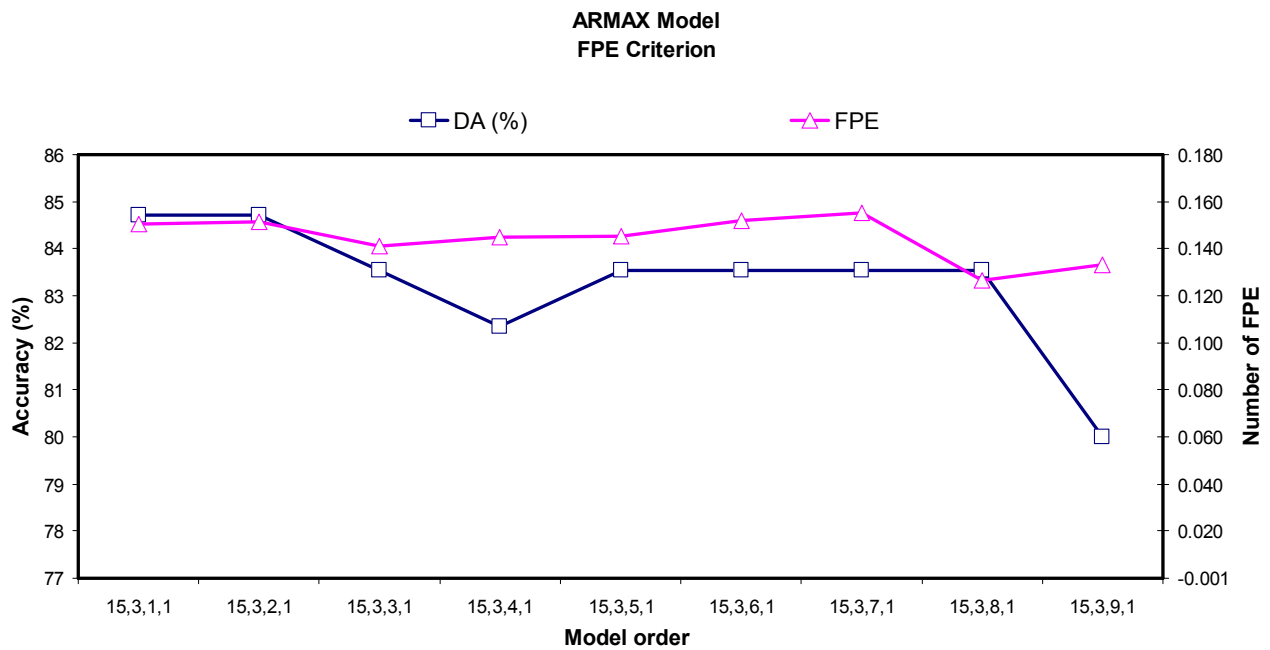

Figure 4. Plot of diagnostic accuracy and FPE against the number of model order using FPE model order criteria via ARMAX model

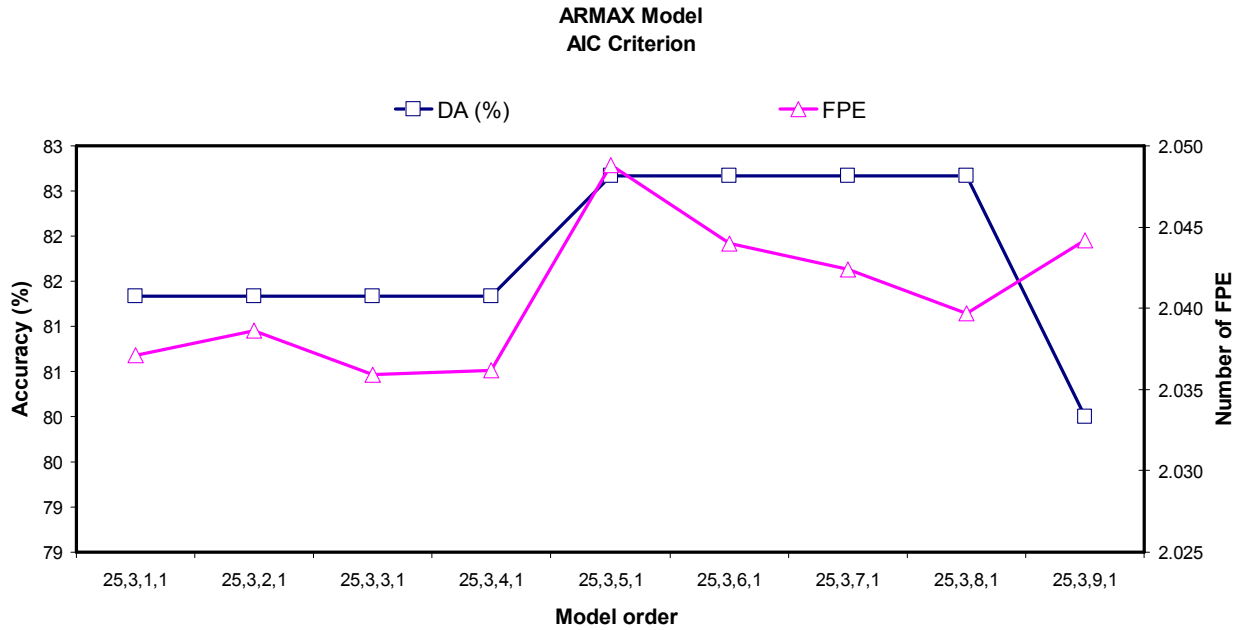

Figure 5. Plot of diagnostic accuracy and FPE against the number of model order using AIC model order criteria via ARMAX model

After the model order had been selected, the next stage is to find the percentage of AUC in different types of model order.

The ROC curve for the ARMAX model is shown in Figure 6. The Lipschitz number for ARMAX model, DA is 84.62%. The closest ED is depicted from the ideal point (0,1) as 0.238 when the optimized model has a threshold of 0.5. The FPE and AIC model order criterion, the closest ED is depicted from the ideal point (0,1) as 0.224 when the optimized model has a threshold of 0.5 as shown in Figure 7 and closest ED is depicted from the ideal point (0,1) as 0.271 when the optimized model has a threshold of 0.6 as shown in Figure 8.

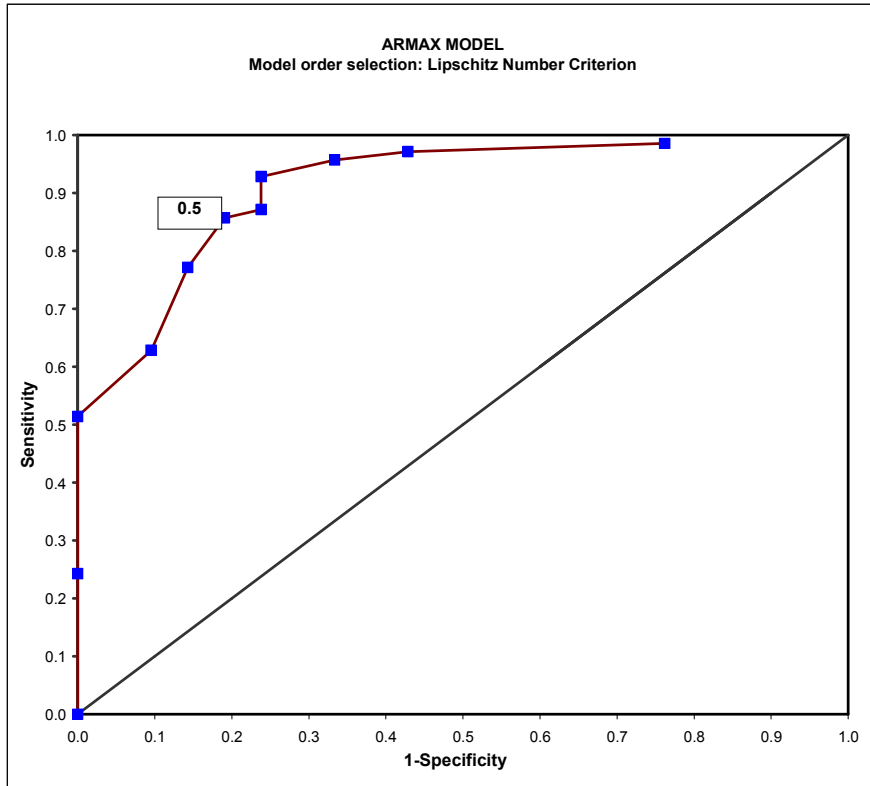

Figure 6. ROC curve for ARMAX model using Lipschitz number criterion

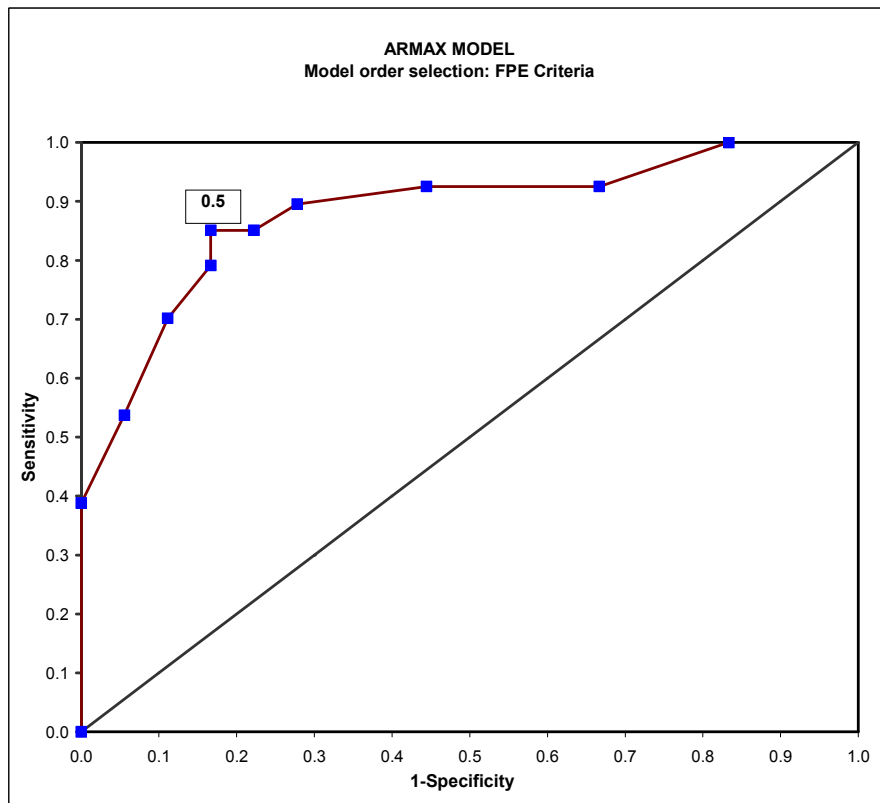

Figure 7. ROC curve for ARMAX model using FPE model order criterion.

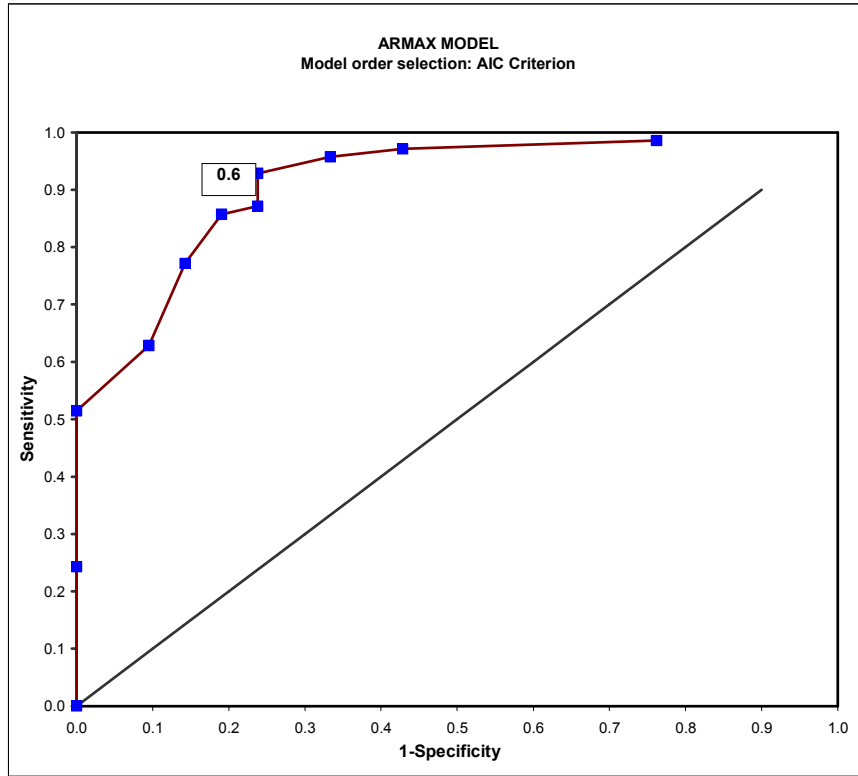

Figure 8. ROC curve for ARMAX model using AIC model order criterion

Table 2 shows the AUC of ARMAX models with the different model order criteria. Based on AUC percentage value, it was found that the Lipschitz number criterion produces the highest accuracy (76.70%) for the ARMAX model.

Table 2: The diagnostic performance of ARMAX models with the different model order criteria.

Criterion	Model order	AUC (%)
Lipschitz	4,2,2,2	76.70
FPE	15,3,1,1	71.30
AIC	25,3,8,1	67.50

All these AUC from the ARMAX models were then compared in order to evaluate the best model for dengue infection diagnosis and are summarized in Table 3 based on sensitivity, specificity, DA and ED, respectively.

Table 3: The accuracy of the diagnostic test using ARMAX models with different model orders.

	Criterion		
	Lipschitz	FPE	AIC
Sensitivity	85.71	85.07	81.67
Specificity	80.95	83.33	80.00
Diagnostic Accuracy	84.62	84.71	81.33
Euclidean Distance from point (0,1)	0.238	0.224	0.271

## VII. CONCLUSIONS

The analysis of the three models order criteria of linear ARMAX indicate that Lipschitz number gives highest accuracy of 76.70% as compared to FPE and AIC criteria. The comprehensive work described in this paper is an effort done towards the development of a novel non-invasive Hb modeling for dengue patients using ARMAX. It has been confirmed that by employing the state of the art bioelectrical impedance technology and system identification model, diagnosing the dengue patients and prediction the status of the haemoglobin concentration could be accomplished.

## ACKNOWLEDGEMENTS

H. Abdul Rahim would like to express her gratitude to Universiti Teknologi Malaysia for supporting her studies.

## REFERENCES

- [1] D.B. Bethell, J. Gamble, P.P. Loc, N.M. Dung, T.T.H. Chau, H.T. Loan, T.T. Thuy, D.T.H. Tam, I.B. Gartside, N.J. White, and N.P.J. Day, "Noninvasive measurement of microvascular leakage in patients with dengue hemorrhagic fever," *Clin. Infect. Dis.*, vol. 32, pp. 243-253, 2001.
- [2] F. Ibrahim, M.N. Taib, S. Sulaiman, and W.A.B. Wan Abas, "Dengue fever (DF) and dengue hemorrhagic fever (DHF) symptoms analysis from an expert system perspective," in *Proc. Proc. of 5<sup>th</sup> IEEE Int. Multi-Topic 2001*, pp. 212-215.
- [3] W. H. Organization, *Dengue Haemorrhagic fever Diagnosis, treatment, Prevention, and control*, 2<sup>nd</sup> ed. Geneva: WHO, 1997.
- [4] F. Ibrahim, M.N. Taib, W.A.B. Wan Abas, C.G. Chan, and S. Sulaiman, "A Novel Approach to Classify Risk in Dengue Hemorrhagic fever (DHF) using Bioelectrical Impedance Analysis," *IEEE Trans. Instrum. Meas.*, vol. 54, no. 1, pp. 237-244, 2005.
- [5] F. Ibrahim, N.A. Ismail, M.N. Taib and W.A.B. Wan Abas, "Modeling of hemoglobin in dengue fever and dengue hemorrhagic fever using bioelectrical impedance " *Physiol. Meas.*, vol. 25, pp. 607-615, 2004.
- [6] Q. Tian, B.S. Sun, A. Ozguler, and S.A. Morris, "Parametric modeling in food package defect imaging," *IEEE Trans. on Ultrasonic, Ferroelectrics and Freq. Contr.*, vol. 47, no. 3, pp. 635-643, 2000.
- [7] H. Wu, D. Sun, Z. Zhou, and S. Xiong, "Model identification of a small-scale air vehicle for loitering control design," *Proc. of IEEE Int. Conf. on Robotics and Automation*, vol. 4, pp. 4035-4040, 2004.
- [8] H. Wu, D. Sun, and Z. Zhou, "Model identification of a micro air vehicle in loitering flight based on attitude performance evaluation," *IEEE Trans. on Robotics*, vol. 20, no. 4, pp. 702-712, 2004.
- [9] A. J. Koivo, "Force-position-velocity control with self-tuning for robotic manipulators," *Proc. of IEEE Int. Conf. on Robotics and Automation*, vol. 3, pp. 1563-1568, 1986.
- [10] C. Hori, K. Itakura, M. Nogawa, M. Shirakabe, I. Kubato, H. Tomoike, and S. Takatani, "Estimation of aortic BP waveform from noninvasive radial tomometry; validation of FFT and ARX models," *Proc. of 19<sup>th</sup> IEEE Int. Conf. on EMBS*, pp. 1142-1145, 1997.
- [11] L. Ljung, *System identification-Theory for the user*: Prentice Hall, Eaglewood Cliffs, New Jersey 1987.
- [12] H. Akaike, "Information theory as an extension of the Maximum Likelihood principle " *In 2<sup>nd</sup> International Symposium on Information Theory*, pp. 267-281, 1973.
- [13] X. He, and H. Asada, "A new method for identifying orders of input-output models for nonlinear dynamic systems," *Proc. of the American Control* pp. 2520-2523, 1993.
- [14] M. Norgaard, "Neural network based on system identification toolbox," *Technical Report, 00-E-891, Department of Automation, Technical University of Denmark*, 2000.
- [15] E. Chungue, J.P. Boutin, and J. Roux, "Antibody capture ELISA for IgM antibody titration in sera for dengue serodiagnosis and surveillance," *Research in Virology*, vol. 140, pp. 229-240, 1989.
- [16] F. Ibrahim, M.N. Taib, W.A.B. Wan Abas, C.C. Guan, and S. Sulaiman, "A novel dengue fever (DF) and dengue haemorrhagic fever (DHF) analysis using artificial neural network," *Compu. Methods Programs Biomed.*, vol. 79, pp. 273-281, 2005.
- [17] A.R. Herlina, I. Fatimah, and T. Mohd Nasir, "A non-invasive system for predicting hemoglobin (Hb) in dengue fever (DF) and dengue hemorrhagic fever (DHF) " in *Proc. Int. Conf. on Sensor and New Techniques in Pharmaceutical and Biomedical Research (ASIASENSE)*, Kuala Lumpur, 2005.



- [18] F. I. H. Abdul Rahim, and M.N. Taib, "Modeling of hemoglobin in dengue infection application," *Journal of Elektrical Engineering (ELEKTRIKA)*, vol. 8, 2006.
- [19] H. Abdul Rahim, F. Ibrahim, and M.N. Taib, "Assessment of Autoregressive (AR) models for dengue infection application," in *Proc. Proc. of the 2nd Int. Colloquium on Signal Processing and its Applications (CSPA 2006)*, Cherating, Pahang, 2006.
- [20] H. Abdul Rahim, F. Ibrahim, and M.N. Taib, "Analysis of linear ARX modeling in the diagnosis of dengue infections," in *Proc. Proc. of the 1st Int. Conference on Control, Instrumentation and Mechatronics (CIM 07)*, Johor Bahru, Johor, 2007.
- [21] F. Ibrahim, "Prognosis of dengue fever and dengue haemorrhagic fever using bioelectrical impedance," Ph.D dissertation, Department of Biomedical Engineering, University of Malaya, July, 2005.