

THE AUTONOMOUS GOLF PLAYING MICRO ROBOT: WITH GLOBAL VISION AND FUZZY LOGIC CONTROLLER

N. G. Jabson, K.G. B. Leong, S. W. Licarte, G. M. S. Oblepias, E. M. J. Palomado, E .P. Dadios

Department of Manufacturing Engineering and Management

De La Salle University, Manila

2401 Taft Ave., Malate, Manila 1004, Philippines

dadiose@dlsu.edu.ph

ABSTRACT - This paper presents design concepts in developing an Autonomous Golf Playing Micro Robot. The robot moves autonomously using 2 DC motors controlled by a remote PC using fuzzy logic system. A servomotor is used for the motion of the putter in hitting the golf ball. A microcontroller is used to process the information sent by the computer through RF communication and drive the robot motors for appropriate motions. The robot plays golf in a defined environment and avoids obstacles. A real golf ball with orange color is use during the game. The system utilizes global camera vision that serves as the eyes of the robot to know its dynamic environment for navigation. The vision system developed detects the position of the robot, golf hole, golf boundaries, and the golf ball within the playing field on real time using color object recognition algorithm. A modified golf tournament between autonomous robot golf player and man operated robot golf player was conducted. Results shows the accuracy and robustness of the autonomous robot developed in performing its tasks.

Keywords – Edutainment Robots, Vision System, Image Processing, Golf Playing Robot, Fuzzy Logic System

I. INTRODUCTION

The technological advances in today's society helped cultivate the path for the development of robots, thus, increasing the roles they play that vary from industrial applications to complex educational and entertaining projects [1]. Due to continuous increase of robots in operation and human's growing reliance on them, it is best that students have fundamental knowledge on robot technology. So as to incorporate fun into learning robotics scientist and researchers chooses sports as a means of presenting the technology in an entertaining and exciting way [2]-[5]. The Autonomous Robotic System for

Playing Mini-Golf was developed to demonstrate robotic applications to engineering students [6]. A golf playing robot called AHAG was created to show how a robot can conform to the different rules of golf and functions [7]. However, limitations were encountered in these researches because of poor navigation due to problems in identifying and locating objects on the field. Robot navigation and path planning is widely researched and still need attention for improvements particularly in dynamic environment [8]-[12].

The autonomous golf playing micro robot (AGPMR) is an excellent platform for developing educational and entertaining robots because golf is a sport that requires sophisticated intelligence, planning, and strategies in order to win the game. Golf game involves knowing the exact position of the ball and determining the best approach in traversing a given fairway. The AGPMR is capable of putting. Putting, just like any other skill in golf, requires good control. The potential of a good golfer to calculate and assess the proper direction and appropriate force to hit the ball into the hole is the key component in sinking the golf ball into the hole. The integration of such human capabilities and intelligence into the robot system is the main interest in this paper.

The next sections presented in this paper are organized as follows: Section 2 discusses the environment and physical structure of the AGPMR. Section 3 discusses the processes involved in designing the controller of the AGPMR. This includes the global vision system and strategies in playing golf. Section 4 discusses the fuzzy logic motion controller for AGPMR. Section 5 presents the experiment results with the analysis and discussions. Finally, section 6 presents the conclusion and future recommendations.

II. THE AUTONOMOUS GOLF PLAYING MICRO ROBOT ENVIRONMENT

In this research, a simulated golf course has been used which is confined in an indoor environment that has an area of 1.2 x 1.6 meters. This field has a wall barrier along its perimeter with a height of 0.1 meter. The ground floor is flat surface covered with green carpet-like cloth. Although real golf rules are adapted into the game minor adjustments are also made. The hole has a diameter of 10.8 centimeters with fixed location and painted pink. The objects seen on the playing field during the game are the real golf ball, the hole, and the micro robot. The micro robot golf playing capability to sink the ball into a hole is through putting.

The intelligence of the robot based on the context of playing golf is derived from the software inside the computer. An RF communication system is used for the robot to receive commands from the computer. A camera is installed on top of the simulated golf course and connected to the computer to serve as the eyes of the system. All decisions or commands coming from the computer for appropriate robot actions are dependent to the images captured by the camera. From this image, information regarding the ball, the golf hole, and the robot location will be extracted and analyzed to come up with navigation strategies. These strategies dictate the robot real time action in performing its task like positioning, putting, and avoiding obstacles. The robot has two dc motors or actuators responsible for its motion. The shaft of each motor is connected to the wheel. Hence, motions of the robot are dependent to the rotation of the left and right wheels.

The actual physical structure of the golf playing micro robot is shown in figure 1. The actual size of the robot is limited to 10 cubic centimeters and has a total weight of not more than 780 grams. The robot structure is composed of the wheels, putter, and body. The wheels are attached almost at the back in order to achieve optimum stability. A ball caster wheel is attached at the center front to stabilize the robot motion. The arm or putter is designed such that the face is wide enough to ensure that it hits the ball and has a long point of contact with the target to hit. This design is based on a flat faced blade type putter. The robot's body includes the back wall, battery door cover, right wall, left wall, front wall, and the robot's cover with the patch.

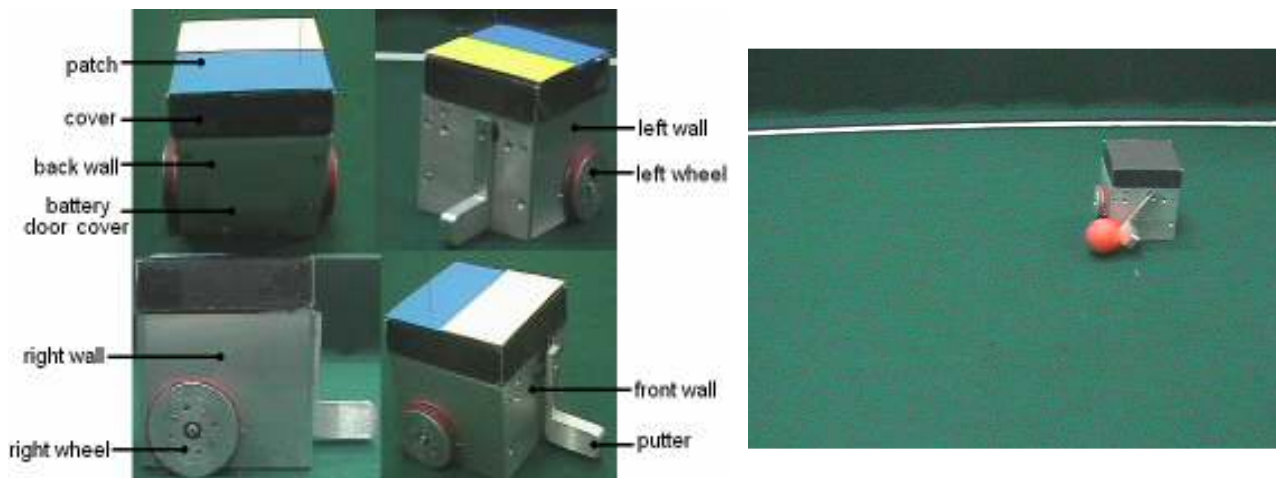

Fig. 1 Physical structure of autonomous golf playing micro robot

III. PROCESSES INVOLVED IN DESIGNNING THE CONTROLLER OF THE AUTONOMOUS GOLF PLAYING MICRO ROBOT

Figure 2 shows the overall process structure of the autonomous golf playing micro robot. The process starts in the camera vision system where images of the golf field are captured and analyzed in the PC. Using these images the fuzzy logic algorithm decides for the actions of the robot. These actions will be sent to the robot from the PC via RF wireless communication system.

A. Vision System for Autonomous Golf Playing Micro Robot

Figure 3 shows the vision system algorithm to identify the objects captured by the camera on a golf playing field. The algorithm uses color object recognition [13], hence, the robot has 2 color patches, the ball has orange color, and the hole has pink color. Initially, it undergoes a color space transformation from RGB to RG-chromaticity space [14]. The hue and saturation were extracted in order to use the pie-slice decision region [15]. The pie-slice decision region is use to binarize the image that will be the input of the labeling process. Once the objects are labeled, size filtering is implemented in order to eliminate labeled pixels that do not match the size of the target object [13]. The centroid of the target object provides the actual object coordinates inside the playing field.

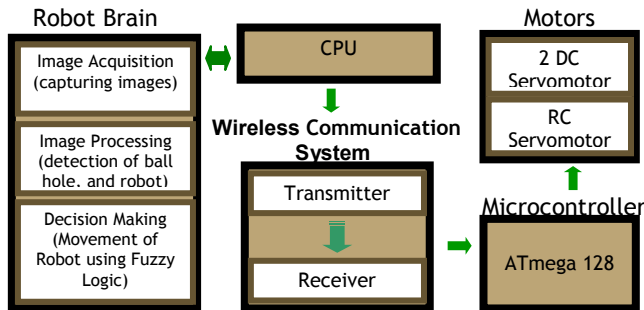

Fig. 2. Overall process architecture of the autonomous golf playing micro robot

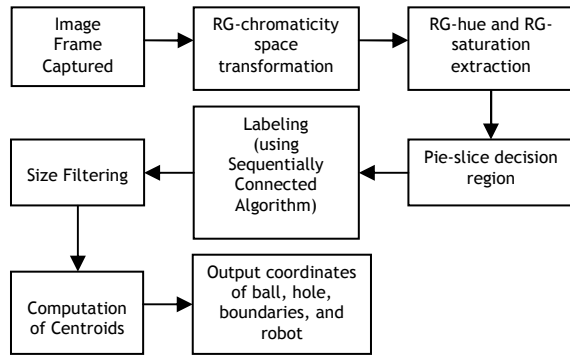

Fig. 3. The autonomous golf playing micro robot vision system algorithm

The setting of the Pie Slice Decision Regions is shown in table 1. When the colored image does not satisfy the condition wherein the hue and saturation is not within the set boundaries, the pixel value will be set to 0, otherwise, it will be set to 255. For the labeling process, the binarized images are flagged depending on what the target color is. For the orange golf ball: the flag is 1, for the yellow patch: the flag is 2, for the blue patch: the flag is 3 and for the pink hole: the flag is 4. Once the flags are set, the sequential connected component labeling algorithm will be used [13]. The flags were also used to trigger which size filtering technique should be implemented. Since the size of the different target colors varies, the size filtering for each target is different. The values set for the size filtering are shown in Table 2.

Table 1. Pie slice decision regions settings

Color	Minimum Hue	Maximum Hue	Minimum Saturation
Yellow	40.8	73.8	0.061
Blue	182.2	215.0	0.164
Orange	334.4	360	0.084
Pink	251.2	332.1	0.054

Table 2. Values for the size filtering

Color	Minimum pixels	Maximum pixels
Orange	20 pixels	100 pixels
Yellow	60 pixels	200 pixels
Blue	60 pixels	200 pixels
Pink	200 pixels	400 pixels

B. Micro Robot Golf Playing Strategies

Figure 4 shows the decisions and strategies algorithm for the micro robot to play golf. The x and y coordinates of the ball, the hole, and the robot would be taken as inputs to the system. The system then checks if the ball is moving. If so then it will send a stop command to the robot. If the ball is not moving then it would check if the ball is inside the hole. When the ball is inside the hole, the game will stop, however, if the ball is not inside the hole then it would check if the location of the ball is inbound or outbound. If it is outbound, the ball needs to be repositioned manually.

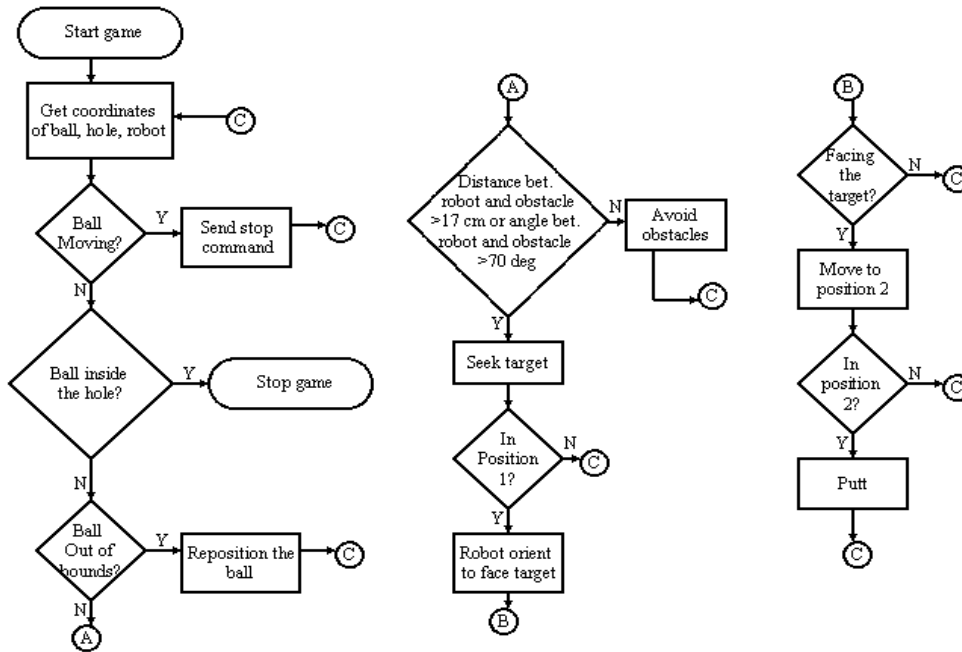

Fig. 4. Program flow of robot decision and strategies

IV. FUZZY LOGIC MOTION CONTROLLER FOR THE AUTONOMOUS GOLF PLAYING MICRO ROBOT

Fuzzy logic was first proposed by Zadeh based on the idea that humans do not think in terms of crisp numbers, but rather in terms of concepts [16], [17]. The application of fuzzy logic in control problem was first introduced by Mamdani [18]. This paper presents fuzzy logic strategy module for the decision algorithm that mimics the way humans think in determining the robot path and position in hitting the ball. The fuzzy logic system approach is implemented in this research because it provides an

effective means of translating how people think into a form that can be easily implemented in the machines [19], [20]. The strategy module in this research is divided into two main functions. The job of the first strategy function is to bring the robot near the position of the ball and avoid obstacles. This strategy function is concerned on positioning the robot perpendicular to the ideal line of path for the ball to travel to reach the hole. This is the first target location which is heuristically placed 18 centimeters away from the ball so that the robot will have ample space to orient itself as it goes to the final target position without bumping the ball. The second strategy function will bring the robot to the final target position which is a location by which the robot shall hit or putt the ball into the hole.

Each strategy function uses fuzzy logic system to generate the velocities of the left and right wheels. The fuzzy logic system uses two inputs \underline{de} and $\underline{\theta e}$ shown in Fig 5. The \underline{de} is the distance between the target point and the robot's centroid. The $\underline{\theta e}$ is the angle difference between the heading angle of the robot and the target position. From Fig 6, the actual values of the parameters used in the fuzzy logic controllers are calculated based from the equations given below. Note that the vision system determines the exact position of the robot, the golf ball, the golf boundaries, and the golf hole in real time. These values are used in the equations below.

$(rx1, ry1)$ = centroid of robot yellow patch

$(rx2, ry2)$ = centroid of robot blue patch

(tx, ty) = centroid of target position

$$rx = (rx2 + rx1) \div 2 \quad (1)$$

$$ry = (ry2 + ry1) \div 2 \quad (2)$$

$$de = \sqrt{(tx - rx)^2 + (ty - ry)^2} \quad (3)$$

$$\theta e = \theta r - \theta d \quad (4)$$

$$\theta r = \tan^{-1} \left(\frac{(ry2 - ry1)}{(rx2 - rx1)} \right) \quad (5)$$

$$\theta d = \tan^{-1} \left(\frac{(ry - ty)}{(rx - tx)} \right) \quad (6)$$

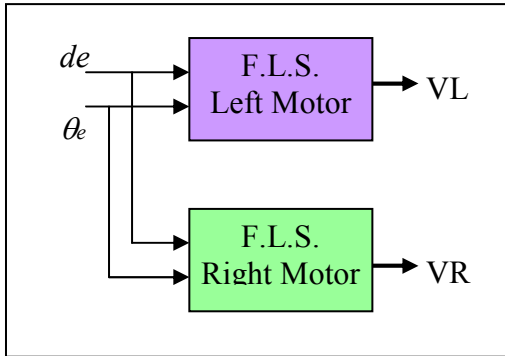

Fig 5. Fuzzy logic controller to generate the robot appropriate motions

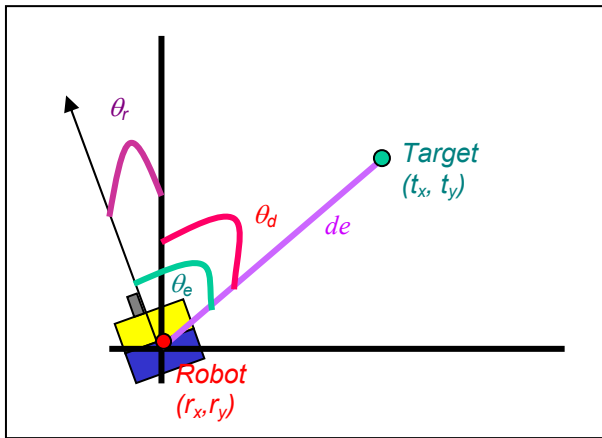

Fig 6. Robot actual orientation with respect to the target location

The input angle θ_e which is the amount of direction by which the robot should turn to face its target can be between positive and negative 180° . A negative value indicates that the robot needs to turn left, otherwise it should turn right. The θ_e for the first strategy module is represented by seven fuzzy linguistic terms namely NL (negatively large), NM (negatively medium), NS (negatively small), ZE (zero), PL (positively large), PM (positively medium) and PS (positively small). The input distance de , on the other hand is represented by four fuzzy linguistic terms namely VN (very near), NR (near), MD (medium) and FR (far).

In the second strategy function, θ_e is represented by five fuzzy linguistic terms namely NM (negatively medium), NS (negatively small), ZE (zero), PM (positively medium) and PS (positively small). The de for this strategy module is represented by two fuzzy linguistic terms namely VN (very

near) and NR (near). The reason for this is that in the second strategy module the range of values of the inputs are narrower because the robot has already approximately reached the position of the ball.

A. Obstacle Avoidance Strategies Using Fuzzy Logic System (FLS)

The golf playing robot obstacle avoidance algorithm varies with respect to the specific obstacle to be avoided. Fig 7 shows a situation where the obstacle to be avoided is a wall. The obstacle avoidance for the walls is designed so that the robot takes the shortest path while avoiding the obstacle. It is dependent on the position of the target with respect to the robot heading angle. The angle between the two is computed and has values from -180 to +180 degrees. If the angle is negative then the target is at the right of the robot, otherwise the target is at the left of the robot. Since the avoidance of a wall is dependent on the position of the target with respect to the robot, the robot should turn in the direction similar to the position of the target. This is done to get the shortest path to the target position.

Figure 8 shows a situation where the obstacle to be avoided is the hole. This does not depend on the position of the target. In here, regardless of the position of target, the robot is directed to make a sharp turn to the left. It does not need to take the shortest path. The direction of the sharp turn to the left was chosen in avoiding the hole so that it would be easier for the robot to position itself since the putter is located at the front left of the robot and the direction of putt is from left to right.

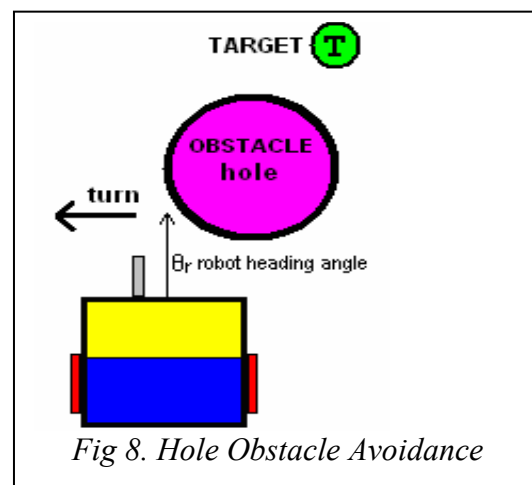
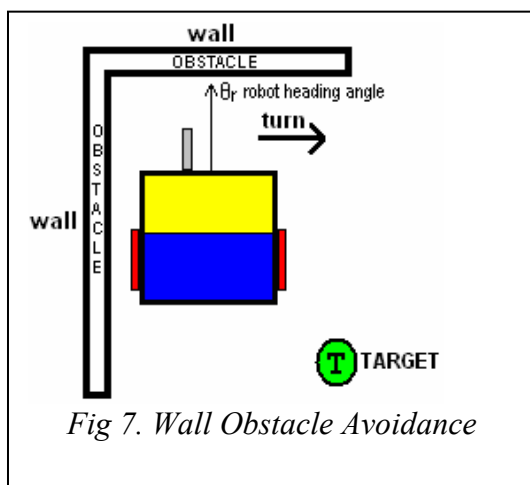
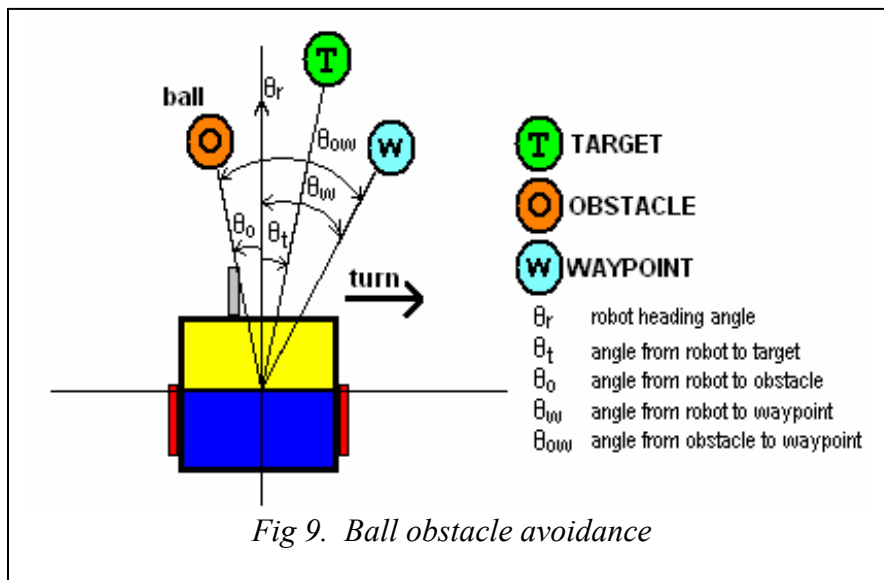

Fig 9 shows the situation where the golf ball is the obstacle to be avoided in going to the target. The target at this point is not yet the golf hole, hence, the obstacle avoidance strategy creates a waypoint and got to that waypoint before going to the desired target position. The assignment of the waypoint should consider the shortest path for the robot to reach the target location. As shown in Fig 11, the obstacle is at the left of the robot and the target is at the right. In this situation the waypoint should be positioned at the right of the robot. If the obstacle is at the right of the robot and the target is at the left, then the waypoint should be positioned at the left of the robot. By default when the obstacle angle and the target angle are the same, the waypoint is assigned to the left of the robot.



In general, there are two inputs considered for the obstacle avoidance fuzzy logic system controller (FLS). The first is the distance of the robot to the obstacle and second is the angle of the obstacle with respect to the heading angle of the robot. The distance between the robot and the obstacle is measured from the center of the robot to the center of the obstacle. The priority for the obstacle avoidance FLS controller is given to the nearest obstacle. When the angle of obstacle obtained is positive then the obstacle detected is at the left of the heading direction of the robot, otherwise it is on the right.

After the inputs to the obstacle avoidance FLS have been identified and defined, fuzzification is conducted by computing the membership of the inputs to their corresponding fuzzy sets. Fig 10 and Fig 11 show the fuzzy membership function of the distance and angle respectively. Table 3 summarizes the definitions of the variables used on the FLS obstacle avoidance controller.

The fuzzy associative memory matrix (FAMM) for the left and right wheels shown in Tables 4 and 5 respectively are used when the obstacle detected is a wall and the target is at the left of the robot. The same FAMM is used when the obstacle detected is the hole. The FAMM in Tables 4 and 5 will just switched when the obstacle detected is a wall and the target is located at the right of the robot. The centroid formula developed by Mamdani is used to calculate the crisp output results [18].

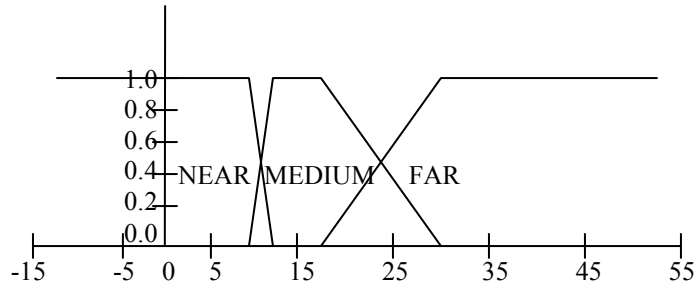

Fig 10. Distance Membership function (d_e) in cm.

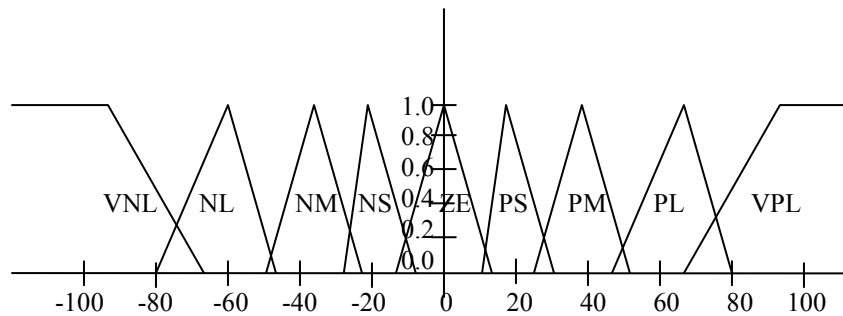

Fig 11. Angle Membership function (θ_e) in degrees

Table 3. Definitions of the variables used in the fuzzy logic obstacle avoidance controller

<p>DISTANCES: N = Near; M = Medium; F = Far</p> <p>ANGLES: VNL = Very Negatively Large NL = Negatively Large NM = Negatively Medium NS = Negatively Small ZE = Zero PS = Positively Small PM = Positively Medium PL = Positively Large VPL = Very Positively Large</p> <p>OUTPUT SPEED: XSN = Very Slow Reverse ZE = Stop (zero) SP = Slow forward</p>
--

Table 4. Left Wheel FAMM

		θ_e								
		NU	NL	NM	NS	ZE	PS	PM	PL	PU
<i>de</i>	NEAR	ZE	ZE	ZE	ZE	XSN	ZE	ZE	ZE	ZE
	MEDIUM	ZE	ZE	ZE	ZE	ZE	ZE	ZE	ZE	ZE
	FAR	ZE	ZE	ZE	ZE	ZE	ZE	ZE	ZE	ZE

(Obstacle = Wall && Target Position = Left) or (Obstacle = Hole)

Table 5. Right Wheel FAMM

		θ_e								
		NU	NL	NM	NS	ZE	PS	PM	PL	PU
<i>de</i>	NEAR	SP	SP	SP	SP	ZE	SP	SP	SP	SP
	MEDIUM	SP	SP	SP	SP	SP	SP	SP	SP	SP
	FAR	SP	SP	SP	SP	SP	SP	SP	SP	SP

(Obstacle = Wall && Target Position = Right) or (Obstacle = Hole)

V. EXPERIMENTAL RESULTS AND ANALYSIS

A. Robot Velocity Test

The robot velocity test checks the capacity of the two DC motors in moving the robot. This determines also the changes of velocities when different data are sent to both motors. Table 3 shows the results gathered for this test. This starts by making a 50 - centimeter mark on the playing field. Transmitting a certain data corresponding to a specified speed, the robot was timed while it runs from the start until the end of the mark. The process is repeated for various data sent to the system. The time it takes for the robot to finish the whole mark under a given speed was recorded. The average time was computed and this was used in finding the velocity of the robot for each transmitted data.

Looking at the last column of table 6, it can be seen that the velocity test was successful because the velocity increases as the transmitted data decreases. Note that data 126 correspond to the slowest speed while 0 correspond to the fastest speed in forward direction. Notice also that the time results for data 36 are set to 0.8 second and 1.03 second and the computed velocity is 54.6448 centimeters per second. This means that the robot can travel 54.6448 centimeters in just a second surpassing the

maximum distance of 50 centimeters set at the start of the experiment. Thus, the dc motors used works very well.

Table 6. Velocity test of the 2 motors used by the robot

Left Motor	Right Motor	Distance Traveled	1st Time (secs)	2nd Time (secs)	Average Time	Velocity (cm/s)
126	126	50 cm	6.57	6.90	6.735	7.4239
120	120	50 cm	6.04	5.26	5.65	8.8496
114	114	50 cm	5.02	4.41	4.715	10.6045
108	108	50 cm	4.09	3.42	3.755	13.3156
102	102	50 cm	3.77	3.28	3.525	14.1844
96	96	50 cm	3.16	2.60	2.88	17.3611
90	90	50 cm	2.51	2.07	2.29	21.8341
84	84	50 cm	2.03	1.66	1.845	27.1003
78	78	50 cm	1.97	1.53	1.75	28.5714
72	72	50 cm	1.75	1.39	1.57	31.8471
66	66	50 cm	1.45	1.30	1.375	36.3636
60	60	50 cm	1.32	1.35	1.335	37.4532
54	54	50 cm	1.20	1.17	1.185	42.1941
48	48	50 cm	1.16	1.12	1.14	43.8596
42	42	50 cm	1.01	1.08	1.045	47.8469
36	36	50 cm	0.8	1.03	0.915	54.6448

B. Putter Test

The putter test determines the farthest distance the ball can travel after being hit by the putter. Comparison of the distances traveled by the ball given different angle combinations was made. An angle combination is the initial angle position of the putter and the final angle position after hitting the ball. The purpose of this is to get the optimum swing of the putter to hit the ball that will give the best distance traveled to shoot the ball. There were two angle combinations chosen and were used for two conditions: (1) when the distance between the ball and hole is far and (2) when the distance between the ball and hole is near. Initial values of the left velocity, right velocity and putter angle data are 127, 127, and 90 degrees respectively signifying the stop condition. In this test, only the putter angle data was being manipulated, leaving the left and right velocity data both at 127, thus the robot wheels are in stop mode. After the ball was hit, the distance it traveled was measured. Ten trials were performed for each angle combination. The bases for choosing the angle combinations were the average distance and the deviation for each angle combination. There were three maximum average distances for maximum putting distance, and three minimum average distances for minimum putting distance selected. The

results of these are shown in Fig 12 and fig 13 respectively. After evaluating many conditions, the angle combination 30-180 was chosen for the maximum putting distance and the angle combination 45-110 for the minimum putting distance. Although the two chosen combinations do not provide the maximum and minimum distance, the two combinations were selected because they provide the least deviation, thus the response is more consistent than that of the other candidates.

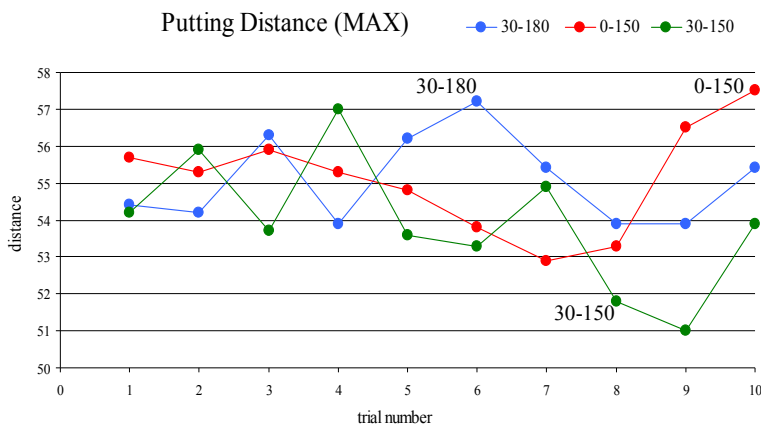

Fig 12. Graph of Candidate Combinations for Maximum Putting Distance

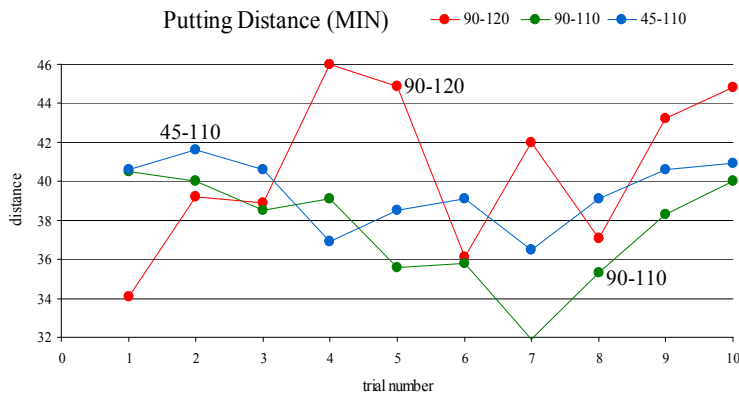

Fig 13. Graph of Candidate Combinations for Minimum Putting Distance

C. Micro Robot Golf Shooting Performance Test

The golf shooting performance test is categorized into automatic robot golf game test and manual robot golf game test. The automatic robot golf game is for the robot to play golf without human intervention. The manual robot golf game is for humans to operate the robot to play golf via computer keyboard. This manual golf game was performed by organizing a mock tournament. Fifteen human participants, divided into five groups were tasked to play a round of golf tournament. A round of golf

tournament consists of three different PAR golf ball locations namely: PAR 6, PAR 5, and PAR 4. Each PAR has different initial distance and ball positions from the golf hole. This round of golf tournament is also applied to the automatic golf game category. The performance of both automatic and manual golf game categories were compared based on the time and number of hits it took the robot to shoot the ball into the hole. Results and comparison between these two modes are presented in tables 7 to 12. The different tables mentioned show the robot's performance in PAR6, PAR5 and PAR4 games. Table 13 shows the final comparison of the results of automatic and manual golf game categories based from the average results of tables 7 to 12. From here, it can be seen that automatic robot golf game category got an average time of 0.952 minutes to shoot the ball while the manual robot golf game category got an average time of 1.88 minutes. The time elapse to shoot the ball in manual game category is higher compared to the automatic game category because the human operator hesitates to activate the putter right away due to human nature of perfectionist behavior. With regards to the number of hits to shoot the ball both manual and automatic game category got the same average hits of 4.27.

However, it is important to note that even though the average hit of the autonomous and manual robot golf game categories are the same the manual robot golf game category had always committed violations and errors during the game, like pushing and touching the ball while positioning the robot to its final target location. Therefore based from these results it can be seen that the autonomous golf playing robot developed exhibit superior performance compared to the manual golf playing robot.

Table 7. Manual game test result for par 6

PAR 6		
	Hits	Time
GAME1	6	02:59.6
GAME2	6	02:32.0
GAME3	7	03:13.1
GAME4	4	01:30.2
GAME5	5	02:55.1
Average	5.6	2.378

Table 8. Manual game test result for par 5

PAR 5		
	Hits	Time
GAME1	6	02:21.2
GAME2	3	01:33.1
GAME3	6	01:49.4
GAME4	5	02:18.0
GAME5	3	02:55.6
Average	4.4	1.952

Table 9. Manual game test result for par 4

PAR 4		
	Hits	Time
GAME1	3	01:20.7
GAME2	2	01:35.6
GAME3	2	01:01.5
GAME4	4	01:50.5
GAME5	2	01:46.4
Average	2.6	1.304

Table 10. Automatic game test result for par 6

PAR 6		
	Hits	Time
GAME1	6	01:33.3
GAME2	4	01:12.1
GAME3	7	01:42.6
GAME4	8	01:40.4
GAME5	5	01:19.3
Average	6.0	1.292

Table 11. Automatic game test result for par 5

PAR 5		
	Hits	time
GAME1	4	01:12.2
GAME2	5	01:20.2
GAME3	2	00:46.4
GAME4	4	01:32.9
GAME5	8	01:46.6
Average	4.6	1.112

Table 12. Automatic game test result for par 4

PAR 4		
	Hits	time
GAME1	3	00:51.1
GAME2	2	00:38.3
GAME3	2	00:45.8
GAME4	2	00:58.8
GAME5	2	00:34.3
Average	2.2	0.452

Table 13. Automatic robot golf game Vs Manual robot golf game

Average results		
	Hits	Time (min)
Automatic golf Game	4.27	0.952
Manual golf Game	4.27	1.88

VI. CONCLUSIONS AND RECOMMENDATIONS

An autonomous golf playing micro robot with global vision has been developed successfully using fuzzy logic controller. The robot developed played golf triumphantly, navigate the playing field, avoid obstacles, and seek for the target autonomously through the use of a camera vision system. A color object detection techniques is used for the vision system which is capable of distinguishing and differentiating the ball, the hole and the robot regardless of different lighting conditions. The wireless communication made it clear that there is a smooth transmission of data between the host computer and the robot.

A new set of golf rules for the golf playing robot was implemented. The robot played golf either operated manually or automatically through the construction of the user interface program, which was achieved using a Graphical User Interface (GUI). The manual game operation had difficulties compared to automatic game operation because it will take more time for human operator to position the robot near the ball before putting. Many times the human operator committed ball touching and pushing violations before putting. Hence, the robot that played golf autonomously exhibit superior performance compared to the robot that played golf with human operator.

In the future, it will be more challenging to develop a real humanoid robot that will play golf using its arm to putt and legs to walk to navigate the playing field.

REFERENCES

- [1] Dowling, Kevin (1996) "Robotics: Frequently Asked Questions", [Online]. Available: <http://www.frc.ri.cmu.edu/robotics-faq>
- [2] J.H.Kim, D.H.Kim, *Soccer Robotics*, Springer, 2004, ISBN: 3540218599
- [3] J. H. Kim, et. al, (2007, June 14) 12th FIRA RoboWorld Cup USA 2007, [Online]. Available www.fira.net
- [4] O. Kaynak (2006, December 6-9) 8th International Robot Olympiad 2006, Gold Coast, Australia, [Online]. Available www.iroc.org
- [5] S. Karad (2008) ABU-ROBOCON 2008 Pune, India, [Online]. Available <http://www.roboconindia.com/index1.asp>
- [6] Jouaneh, M. & Carnevale, P., "Autonomous Robotic System for Playing Mini-Golf", IEEE Robotics and Automation Magazine, Courtesy of The Center for Robotics & Automation Research, University of Rhode Island, June 2003.
- [7] N. Cane, E. Moseley, J. Saunders (2006, February 16) A.H.A.G. – The Miniature Golf Playing Robot, [Online]. Available <http://www.cs.bham.ac.uk/resources/courses/robotics/halloffame/2002/team9/>,
- [8] R. B. Tilove, "Local obstacle avoidance for mobile robots based on the method of artificial potentials,". In *Proc. IEEE Conf. Robotics Automtion*, Cincinnati, OH, 1990, 566-71.
- [9] P. Wolfs, et. al. "Simple Strategies for Collision-Avoidance in Robot-soccer,". In *Proc Micro-Robot World Cup Soccer Tournament*, KAIST, Taejon, Korea, 1996, pp 64-67
- [10] C. Zhang, L. Wu, X. Xu, "Real-time Navigation and Obstacle Avoidance for Robot Soccer Player," In *Proc International Symposium on Autonomous Robots and Agents*, Singapore, 2000, pp 28-31.
- [11] A. R. Brooks, "Solving the find-path problem by good representation of free space," *IEEE Trans. Syst. Man, Cybern.*, vol.SMS-13,1983, 190-197.
- [12] T. Semeon, S. Leroy, J. P. Laumond, "Path Coordination for Multiple Mobile Robots: A Resolution Complete Algorithm," *IEEE Transactions on Robotics and Automation*, Vol. 18, No. 1, pp. 42-48, Feb. 2002.
- [13] N. H. Reyes, E. P. Dadios, "Dynamic Color Object Recognition Using Fuzzy Logic," *Journal of Advanced Computational Intelligence and Intelligent Informatics*, Vol 8 No. 1, pp 29-37, FUJI Technology Press, January 2004.
- [14] P. J. Thomas, R. J. Stonier and P. J. Wolfs, "Robustness of Color Detection for Robot Soccer," In *Proc of the Seventh International Conference on Control, Automation, Robotics and Vision, ICARCV 2002*, Singapore, 7480-6, pp. 1245-1249, December, (2002).
- [15] N. Reyes, E. P. Dadios, "A Fuzzy Approach in Color Object Detection," In *Proc. of IEEE International Conference on Industrial Technology*, Bangkok, Thailand, pp. 232-237, Dec. 11-14, 2002.
- [16] L. A. Zadeh, R. R. Yager, "An Introduction to Fuzzy Logic Applications in Intelligent Systems," *Klumer Academic Pub*, pp. 69-89
- [17] L. A. Zadeh, "Fuzzy Sets," *Information and control*, Vol. 8, pp338-353, 1965.
- [18] E. H. Mamdani, "Application Of Fuzzy Algorithm for the Control of a dynamic plant," *IEEE Proc.*, Vol.21., 1974, pp1585-1588.
- [19] E. Maravillas, E.P. Dadios, "Hybrid Fuzzy Logic Strategy for Soccer Robot Game," *Journal of Advanced Computational Intelligence and Intelligent Informatics*, Vol 8 No. 1, pp 65-71, FUJI Technology Press, January 2004.
- [20] O. Maravillas, E. P. Dadios, "Fuzzy Logic Controller for Micro Robot Soccer Game," In *Proc of the 27th Annual Conference of the IEEE Industrial Electronics Society (IECON'01)*, Hyatt Regency Tech Center, Denver, Colorado, USA, pp. 2154-2159, Nov. 29 – Dec. 2, 2001